



Stones

MYMESIA

Stone picker for small and medium stones

The **MYMESIA** stone picker is the latest model to join our range of JYMPA continuous-loading rotor stone pickers. Evolved from the successful MYMERTIA model, this new model has a simpler and more robust rotor that collects stones up to 40 cm in diameter, making this model very versatile and easy to operate and maintain.

The spring cushioning and the floating shaft ensure the safety of the rotor against strong impacts. The model with double chassis (DX) allows a higher unloading height.

“Great versatility”



Model MYM-185-RN

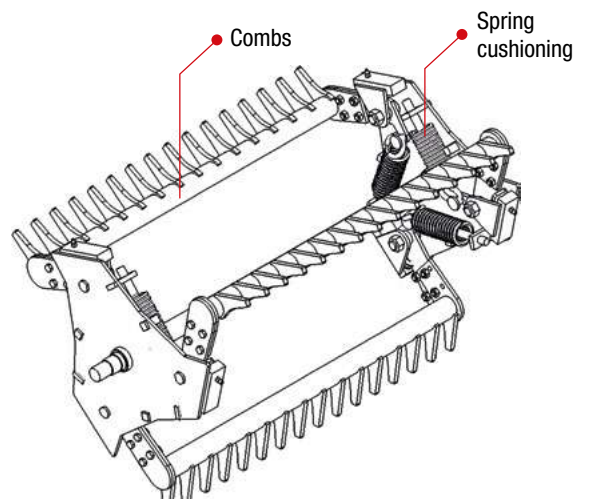

Rotor MYMESIA

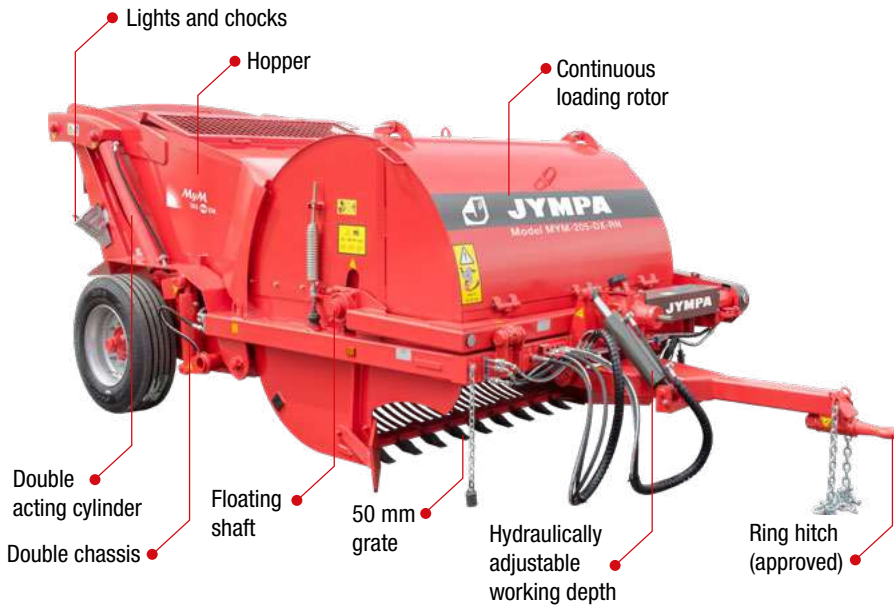

Modelo MYM-205-AM-RN



EUROPEAN TYPE-APPROVAL

No. 167/2013

On the approval and market surveillance of agricultural and forestry vehicles

Optional elements:

- 70 mm, 40 mm and 30 mm grate
- K80 hitch
- 12,5/80-15,3 wheels for MYM-185-RN
- 285/70-19,5 wheels for MYM-185-RN



Rotor MYMESIA

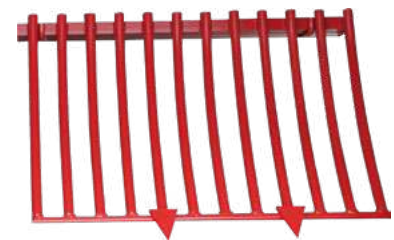

Grate: in options of 70 mm, 40 mm or 30 mm

Model	Required power HP	Machine width m	Working width m	Height m	Length m	Volume m ³	Unloading height	No. rake tines	Tyres	Approximate weight kg
MYM-185-RN	60-80	2,10	2,10	2,04	4,97	2,70	1,82	8	11,5/80-15,3	2.700
MYM-205-AM-RN	70-90	2,48	2,48	2,04	5,50	3,30	1,82	9	285/70-19,5	3.620
MYM-205-DX-RN	70-90	2,48	2,48	2,04	5,50	3,30	2,40	9	285/70-19,5	3.800